

Trapezgewindespindeln

Trapezgewindespindeln eingängig rechts

Trapezgewindespindeln eingängig links

Trapezgewindespindeln zweigängig rechts

Sonderanfertigungen nach Zeichnung sowie
Standardteile einbaufertig bearbeitet,
auf Wunsch mit Wärme- und/oder Oberflächenbehandlung



www.GG-ANTRIEBSTECHNIK.DE

Trapezgewindespindeln

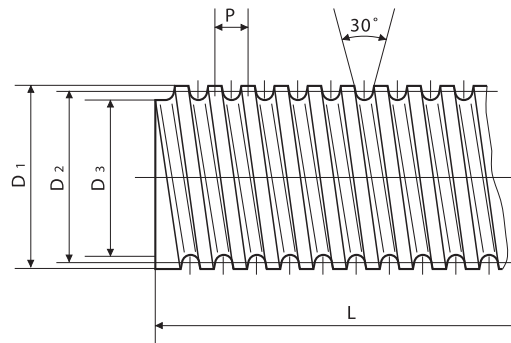

Trapezgewindespindeln eingängig rechts C35

G&G-Best.-Nr.	DxP	L	D1 max	D1 min	D2 max	D2 min	D3 max	D3 min	Steigungswinkel
700-010-0100	10 x 2	1000	10	9.820	8.929	8.739	7.500	6.890	4°07'
700-010-0200	10 x 2	2000	10	9.820	8.929	8.739	7.500	6.890	4°07'
700-010-0300	10 x 2	3000	10	9.820	8.929	8.739	7.500	6.890	4°07'
700-012-0100	12 x 3	1000	12	11.764	10.415	10.191	8.500	7.685	5°17'
700-012-0200	12 x 3	2000	12	11.764	10.415	10.191	8.500	7.685	5°17'
700-012-0300	12 x 3	3000	12	11.764	10.415	10.191	8.500	7.685	5°17'
700-014-0100	14 x 3	1000	14	13.764	12.415	12.191	10.500	9.685	4°26'
700-014-0200	14 x 3	2000	14	13.764	12.415	12.191	10.500	9.685	4°26'
700-014-0300	14 x 3	3000	14	13.764	12.415	12.191	10.500	9.685	4°26'
700-014-0104	14 x 4	1000	14	13.700	11.905	11.640	9.500	8.569	6°11'
700-014-0204	14 x 4	2000	14	13.700	11.905	11.640	9.500	8.569	6°11'
700-014-0304	14 x 4	3000	14	13.700	11.905	11.640	9.500	8.569	6°11'
700-016-0102	16 x 2	1000	16	15.820	14.929	14.729	13.500	12.950	2°46'
700-016-0202	16 x 2	2000	16	15.820	14.929	14.729	13.500	12.950	2°46'
700-016-0302	16 x 2	3000	16	15.820	14.929	14.729	13.500	12.950	2°46'
700-016-0100	16 x 4	1000	16	15.700	13.905	13.640	11.500	10.474	5°16'
700-016-0200	16 x 4	2000	16	15.700	13.905	13.640	11.500	10.474	5°16'
700-016-0300	16 x 4	3000	16	15.700	13.905	13.640	11.500	10.474	5°16'
700-018-0100	18 x 4	1000	18	17.700	15.905	15.640	13.500	12.474	4°36'
700-018-0200	18 x 4	2000	18	17.700	15.905	15.640	13.500	12.474	4°36'
700-018-0300	18 x 4	3000	18	17.700	15.905	15.640	13.500	12.474	4°36'
700-020-0100	20 x 4	1000	20	19.700	17.905	17.640	15.500	14.474	4°05'
700-020-0200	20 x 4	2000	20	19.700	17.905	17.640	15.500	14.474	4°05'
700-020-0300	20 x 4	3000	20	19.700	17.905	17.640	15.500	14.474	4°05'
700-022-0100	22 x 5	1000	22	21.665	19.394	19.114	16.500	15.294	4°43'
700-022-0200	22 x 5	2000	22	21.665	19.394	19.114	16.500	15.294	4°43'
700-022-0300	22 x 5	3000	22	21.665	19.394	19.114	16.500	15.294	4°43'
700-024-0100	24 x 5	1000	24	23.665	21.394	21.094	18.500	17.269	4°17'
700-024-0200	24 x 5	2000	24	23.665	21.394	21.094	18.500	17.269	4°17'
700-024-0300	24 x 5	3000	24	23.665	21.394	21.094	18.500	17.269	4°17'

DIN 103 Toleranz 7e
Geradheit 0,2 - 1,0 / 300mm
Steigungsgenauigkeit 0,05 - 0,2 / 300mm

Eingängig rechts gerollt
Material C35



www.GG-ANTRIEBSTECHNIK.DE

Trapezgewindespindeln

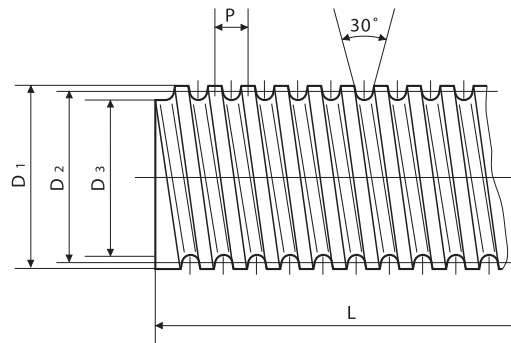

Trapezgewindespindeln eingängig rechts C35

G&G-Best.-Nr.	DxP	L	D1 max	D1 min	D2 max	D2 min	D3 max	D3 min	Steigungswinkel
700-026-0100	26 x 5	1000	26	25.665	23.394	23.094	20.500	19.269	3°55'
700-026-0200	26 x 5	2000	26	25.665	23.394	23.094	20.500	19.269	3°55'
700-026-0300	26 x 5	3000	26	25.665	23.394	23.094	20.500	19.269	3°55'
700-028-0100	28 x 5	1000	28	27.665	25.394	25.094	22.500	21.269	3°36'
700-028-0200	28 x 5	2000	28	27.665	25.394	25.094	22.500	21.269	3°36'
700-028-0300	28 x 5	3000	28	27.665	25.394	25.094	22.500	21.269	3°36'
700-030-0100	30 x 6	1000	30	29.625	26.882	26.547	23.000	21.563	4°05'
700-030-0200	30 x 6	2000	30	29.625	26.882	26.547	23.000	21.563	4°05'
700-030-0300	30 x 6	3000	30	29.625	26.882	26.547	23.000	21.563	4°05'
700-032-0100	32 x 6	1000	32	31.625	28.882	28.547	25.000	23.563	3°48'
700-032-0200	32 x 6	2000	32	31.625	28.882	28.547	25.000	23.563	3°48'
700-032-0300	32 x 6	3000	32	31.625	28.882	28.547	25.000	23.563	3°48'
700-036-0100	36 x 6	1000	36	35.625	32.882	32.547	29.000	27.563	3°20'
700-036-0200	36 x 6	2000	36	35.625	32.882	32.547	29.000	27.563	3°20'
700-036-0300	36 x 6	3000	36	35.625	32.882	32.547	29.000	27.563	3°20'
700-040-0100	40 x 7	1000	40	39.575	36.375	36.020	32.000	30.381	3°31'
700-040-0200	40 x 7	2000	40	39.575	36.375	36.020	32.000	30.381	3°31'
700-040-0300	40 x 7	3000	40	39.575	36.375	36.020	32.000	30.381	3°31'
700-044-0100	44 x 7	1000	44	43.575	40.375	40.020	36.000	34.381	3°10'
700-044-0200	44 x 7	2000	44	43.575	40.375	40.020	36.000	34.381	3°10'
700-044-0300	44 x 7	3000	44	43.575	40.375	40.020	36.000	34.381	3°10'
700-050-0100	50 x 8	1000	50	49.550	45.868	45.468	41.000	39.168	3°11'
700-050-0200	50 x 8	2000	50	49.550	45.868	45.468	41.000	39.168	3°11'
700-050-0300	50 x 8	3000	50	49.550	45.868	45.468	41.000	39.168	3°11'
700-055-0100	55 x 9	1000	55	54.500	50.360	49.935	45.000	42.979	3°16'
700-055-0200	55 x 9	2000	55	54.500	50.360	49.935	45.000	42.979	3°16'
700-055-0300	55 x 9	3000	55	54.500	50.360	49.935	45.000	42.979	3°16'
700-060-0100	60 x 9	1000	60	59.500	55.360	54.935	50.000	47.979	2°58'
700-060-0200	60 x 9	2000	60	59.500	55.360	54.935	50.000	47.979	2°58'
700-060-0300	60 x 9	3000	60	59.500	55.360	54.935	50.000	47.979	2°58'

DIN 103 Toleranz 7e
Geradheit 0,2 - 1,0 / 300mm
Steigungsgenauigkeit 0,05 - 0,2 / 300mm

Eingängig rechts gerollt
Material C35

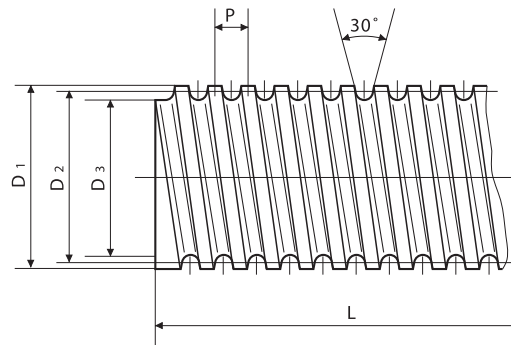

Trapezgewindespindeln eingängig rechts C35

G&G-Best.-Nr.	DxP	L	D1 max	D1 min	D2 max	D2 min	D3 max	D3 min	Steigungswinkel
700-070-0100	70 x 10	1000	70	69.470	64.350	64.425	59.000	56.819	2°49'
700-070-0200	70 x 10	2000	70	69.470	64.350	64.425	59.000	56.819	2°49'
700-070-0300	70 x 10	3000	70	69.470	64.350	64.425	59.000	56.819	2°49'
700-080-0100	80 x 10	1000	80	79.470	74.350	74.425	69.000	66.819	2°27'
700-080-0200	80 x 10	2000	80	79.470	74.350	74.425	69.000	66.819	2°27'
700-080-0300	80 x 10	3000	80	79.470	74.350	74.425	69.000	66.819	2°27'
700-090-0100	90 x 12	1000	90	89.400	83.840	83.365	77.000	74.446	2°36'
700-090-0200	90 x 12	2000	90	89.400	83.840	83.365	77.000	74.446	2°36'
700-090-0300	90 x 12	3000	90	89.400	83.840	83.365	77.000	74.446	2°36'
700-095-0100	95 x 16	1000	95	94.296	86.810	86.250	77.000	73.710	3°22'
700-095-0200	95 x 16	2000	95	94.296	86.810	86.250	77.000	73.710	3°22'
700-095-0300	95 x 16	3000	95	94.296	86.810	86.250	77.000	73.710	3°22'
700-100-0100	100 x 16	1000	100	99.290	91.810	91.250	82.000	78.710	3°11'
700-100-0200	100 x 16	2000	100	99.290	91.810	91.250	82.000	78.710	3°11'
700-100-0300	100 x 16	3000	100	99.290	91.810	91.250	82.000	78.710	3°11'
700-120-0100	120 x 16	1000	120	119.290	111.810	111.250	102.000	98.710	2°36'
700-120-0200	120 x 16	2000	120	119.290	111.810	111.250	102.000	98.710	2°36'
700-120-0300	120 x 16	3000	120	119.290	111.810	111.250	102.000	98.710	2°36'

DIN 103 Toleranz 7e
 Geradheit 0,2 - 1,0 / 300mm
 Steigungsgenauigkeit 0,05 - 0,2 / 300mm

Eingängig rechts gerollt
 Material C35



www.GG-ANTRIEBSTECHNIK.DE

Trapezgewindespindeln

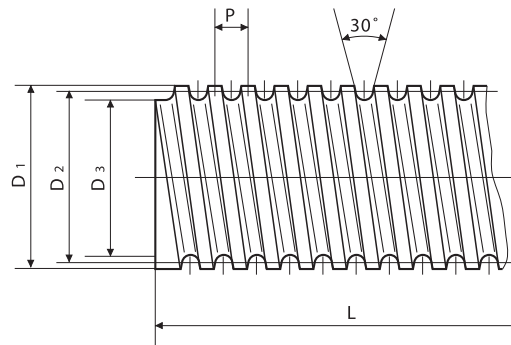

Trapezgewindespindeln eingängig rechts rostfrei

G&G-Best.-Nr.	DxP	L	D1 max	D1 min	D2 max	D2 min	D3 max	D3 min	Steigungswinkel
700-010-6100	10 x 2	1000	10	9.820	8.929	8.739	7.500	6.890	4°07'
700-010-6200	10 x 2	2000	10	9.820	8.929	8.739	7.500	6.890	4°07'
700-010-6300	10 x 2	3000	10	9.820	8.929	8.739	7.500	6.890	4°07'
700-012-6100	12 x 3	1000	12	11.764	10.415	10.191	8.500	7.685	5°17'
700-012-6200	12 x 3	2000	12	11.764	10.415	10.191	8.500	7.685	5°17'
700-012-6300	12 x 3	3000	12	11.764	10.415	10.191	8.500	7.685	5°17'
700-014-6100	14 x 3	1000	14	13.764	12.415	12.191	10.500	9.685	4°26'
700-014-6200	14 x 3	2000	14	13.764	12.415	12.191	10.500	9.685	4°26'
700-014-6300	14 x 3	3000	14	13.764	12.415	12.191	10.500	9.685	4°26'
700-016-6100	16 x 4	1000	16	15.700	13.905	13.640	11.500	10.800	5°16'
700-016-6200	16 x 4	2000	16	15.700	13.905	13.640	11.500	10.800	5°16'
700-016-6300	16 x 4	3000	16	15.700	13.905	13.640	11.500	10.800	5°16'
700-018-6100	18 x 4	1000	18	17.700	15.905	15.640	13.500	12.800	4°36'
700-018-6200	18 x 4	2000	18	17.700	15.905	15.640	13.500	12.800	4°36'
700-018-6300	18 x 4	3000	18	17.700	15.905	15.640	13.500	12.800	4°36'
700-020-6100	20 x 4	1000	20	19.700	17.905	17.640	15.500	14.800	4°05'
700-020-6200	20 x 4	2000	20	19.700	17.905	17.640	15.500	14.800	4°05'
700-020-6300	20 x 4	3000	20	19.700	17.905	17.640	15.500	14.800	4°05'
700-022-6100	22 x 5	1000	22	21.665	19.394	19.114	16.500	15.500	4°43'
700-022-6200	22 x 5	2000	22	21.665	19.394	19.114	16.500	15.500	4°43'
700-022-6300	22 x 5	3000	22	21.665	19.394	19.114	16.500	15.500	4°43'
700-024-6100	24 x 5	1000	24	23.665	21.394	21.094	18.500	17.500	4°17'
700-024-6200	24 x 5	2000	24	23.665	21.394	21.094	18.500	17.500	4°17'
700-024-6300	24 x 5	3000	24	23.665	21.394	21.094	18.500	17.500	4°17'
700-026-6100	26 x 5	1000	26	25.665	23.394	23.094	20.500	19.500	3°55'
700-026-6200	26 x 5	2000	26	25.665	23.394	23.094	20.500	19.500	3°55'
700-026-6300	26 x 5	3000	26	25.665	23.394	23.094	20.500	19.500	3°55'
700-028-6100	28 x 5	1000	28	27.665	25.394	25.094	22.500	21.500	3°36'
700-028-6200	28 x 5	2000	28	27.665	25.394	25.094	22.500	21.500	3°36'
700-028-6300	28 x 5	3000	28	27.665	25.394	25.094	22.500	21.500	3°36'

DIN 103 Toleranz 7e
Geradheit 0,2 - 1,5 / 300mm
Steigungsgenauigkeit 0,1 - 0,3 / 300mm

Eingängig rechts gerollt
Material 1.4404



www.GG-ANTRIEBSTECHNIK.DE

Trapezgewindespindeln

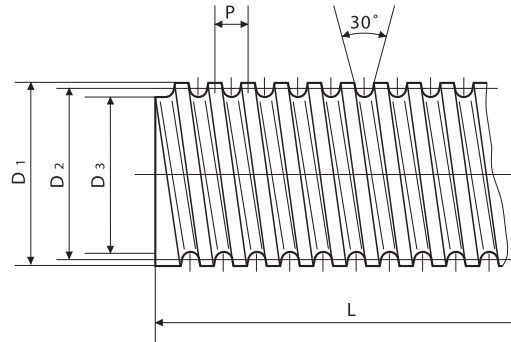

Trapezgewindespindeln eingängig rechts rostfrei

G&G-Best.-Nr.	DxP	L	D1 max	D1 min	D2 max	D2 min	D3 max	D3 min	Steigungswinkel
700-030-6100	30 x 6	1000	30	29.625	26.882	26.547	23.000	21.900	4°05'
700-030-6200	30 x 6	2000	30	29.625	26.882	26.547	23.000	21.900	4°05'
700-030-6300	30 x 6	3000	30	29.625	26.882	26.547	23.000	21.900	4°05'
700-032-6100	32 x 6	1000	32	31.625	28.882	28.547	25.000	23.900	3°48'
700-032-6200	32 x 6	2000	32	31.625	28.882	28.547	25.000	23.900	3°48'
700-032-6300	32 x 6	3000	32	31.625	28.882	28.547	25.000	23.900	3°48'
700-036-6100	36 x 6	1000	36	35.625	32.882	32.547	29.000	27.900	3°20'
700-036-6200	36 x 6	2000	36	35.625	32.882	32.547	29.000	27.900	3°20'
700-036-6300	36 x 6	3000	36	35.625	32.882	32.547	29.000	27.900	3°20'
700-040-6100	40 x 7	1000	40	39.575	36.375	36.020	32.000	30.500	3°31'
700-040-6200	40 x 7	2000	40	39.575	36.375	36.020	32.000	30.500	3°31'
700-040-6300	40 x 7	3000	40	39.575	36.375	36.020	32.000	30.500	3°31'
700-050-6100	50 x 8	1000	50	49.550	45.868	45.468	41.000	39.168	3°11'
700-050-6200	50 x 8	2000	50	49.550	45.868	45.468	41.000	39.168	3°11'
700-050-6300	50 x 8	3000	50	49.550	45.868	45.468	41.000	39.168	3°11'

DIN 103 Toleranz 7e
Geradheit 0,2 - 1,5 / 300mm
Steigungsgenauigkeit 0,1 - 0,3 / 300mm

Eingängig rechts gerollt
Material 1.4404



www.GG-ANTRIEBSTECHNIK.DE

Trapezgewindespindeln

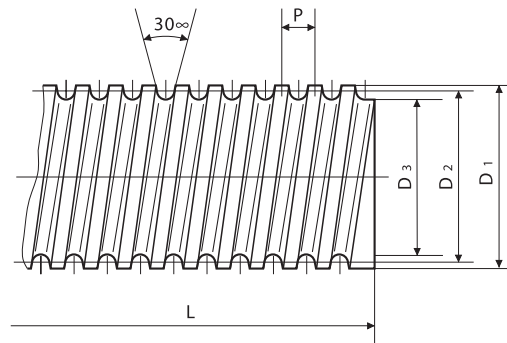

Trapezgewindespindeln eingängig links C35

G&G-Best.-Nr.	DxP	L	D1 max	D1 min	D2 max	D2 min	D3 max	D3 min	Steigungswinkel
705-010-0100	10 x 2	1000	10	9.820	8.929	8.739	7.500	6.890	4°07'
705-010-0200	10 x 2	2000	10	9.820	8.929	8.739	7.500	6.890	4°07'
705-010-0300	10 x 2	3000	10	9.820	8.929	8.739	7.500	6.890	4°07'
705-012-0100	12 x 3	1000	12	11.764	10.415	10.191	8.500	7.685	5°17'
705-012-0200	12 x 3	2000	12	11.764	10.415	10.191	8.500	7.685	5°17'
705-012-0300	12 x 3	3000	12	11.764	10.415	10.191	8.500	7.685	5°17'
705-014-0100	14 x 3	1000	14	13.764	12.415	12.191	10.500	9.685	4°26'
705-014-0200	14 x 3	2000	14	13.764	12.415	12.191	10.500	9.685	4°26'
705-014-0300	14 x 3	3000	14	13.764	12.415	12.191	10.500	9.685	4°26'
705-016-0100	16 x 4	1000	16	15.700	13.905	13.640	11.500	10.474	5°16'
705-016-0200	16 x 4	2000	16	15.700	13.905	13.640	11.500	10.474	5°16'
705-016-0300	16 x 4	3000	16	15.700	13.905	13.640	11.500	10.474	5°16'
705-018-0100	18 x 4	1000	18	17.700	15.905	15.640	13.500	12.474	4°36'
705-018-0200	18 x 4	2000	18	17.700	15.905	15.640	13.500	12.474	4°36'
705-018-0300	18 x 4	3000	18	17.700	15.905	15.640	13.500	12.474	4°36'
705-020-0100	20 x 4	1000	20	19.700	17.905	17.640	15.500	14.474	4°05'
705-020-0200	20 x 4	2000	20	19.700	17.905	17.640	15.500	14.474	4°05'
705-020-0300	20 x 4	3000	20	19.700	17.905	17.640	15.500	14.474	4°05'
705-022-0100	22 x 5	1000	22	21.665	19.394	19.114	16.500	15.294	4°43'
705-022-0200	22 x 5	2000	22	21.665	19.394	19.114	16.500	15.294	4°43'
705-022-0300	22 x 5	3000	22	21.665	19.394	19.114	16.500	15.294	4°43'
705-024-0100	24 x 5	1000	24	23.665	21.394	21.094	18.500	17.269	4°17'
705-024-0200	24 x 5	2000	24	23.665	21.394	21.094	18.500	17.269	4°17'
705-024-0300	24 x 5	3000	24	23.665	21.394	21.094	18.500	17.269	4°17'
705-026-0100	26 x 5	1000	26	25.665	23.394	23.094	20.500	19.269	3°55'
705-026-0200	26 x 5	2000	26	25.665	23.394	23.094	20.500	19.269	3°55'
705-026-0300	26 x 5	3000	26	25.665	23.394	23.094	20.500	19.269	3°55'
705-028-0100	28 x 5	1000	28	27.665	25.394	25.094	22.500	21.269	3°36'
705-028-0200	28 x 5	2000	28	27.665	25.394	25.094	22.500	21.269	3°36'
705-028-0300	28 x 5	3000	28	27.665	25.394	25.094	22.500	21.269	3°36'

DIN 103 Toleranz 7e
 Geradheit 0,2 - 1,0 / 300mm
 Steigungsgenauigkeit 0,05 - 0,2 / 300mm

Eingängig links gerollt
 Material C35



www.GG-ANTRIEBSTECHNIK.DE

Trapezgewindespindeln

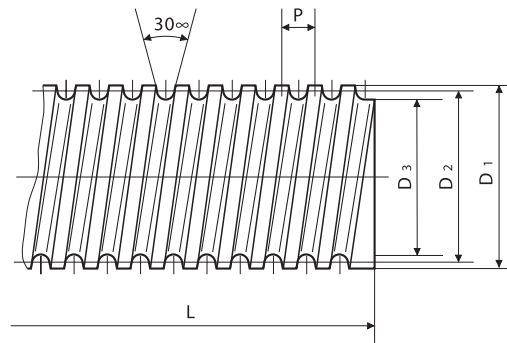

Trapezgewindespindeln eingängig links C35

G&G-Best.-Nr.	DxP	L	D1 max	D1 min	D2 max	D2 min	D3 max	D3 min	Steigungswinkel
705-030-0100	30 x 6	1000	30	29.625	26.882	26.547	23.000	21.563	4°05'
705-030-0200	30 x 6	2000	30	29.625	26.882	26.547	23.000	21.563	4°05'
705-030-0300	30 x 6	3000	30	29.625	26.882	26.547	23.000	21.563	4°05'
705-032-0100	32 x 6	1000	32	31.625	28.882	28.547	25.000	23.563	3°48'
705-032-0200	32 x 6	2000	32	31.625	28.882	28.547	25.000	23.563	3°48'
705-032-0300	32 x 6	3000	32	31.625	28.882	28.547	25.000	23.563	3°48'
705-036-0100	36 x 6	1000	36	35.625	32.882	32.547	29.000	27.563	3°20'
705-036-0200	36 x 6	2000	36	35.625	32.882	32.547	29.000	27.563	3°20'
705-036-0300	36 x 6	3000	36	35.625	32.882	32.547	29.000	27.563	3°20'
705-040-0100	40 x 7	1000	40	39.575	36.375	36.020	32.000	30.381	3°31'
705-040-0200	40 x 7	2000	40	39.575	36.375	36.020	32.000	30.381	3°31'
705-040-0300	40 x 7	3000	40	39.575	36.375	36.020	32.000	30.381	3°31'
705-044-0100	44 x 7	1000	44	43.575	40.375	40.020	36.000	34.381	3°10'
705-044-0200	44 x 7	2000	44	43.575	40.375	40.020	36.000	34.381	3°10'
705-044-0300	44 x 7	3000	44	43.575	40.375	40.020	36.000	34.381	3°10'
705-050-0100	50 x 8	1000	50	49.550	45.868	45.468	41.000	39.168	3°11'
705-050-0200	50 x 8	2000	50	49.550	45.868	45.468	41.000	39.168	3°11'
705-050-0300	50 x 8	3000	50	49.550	45.868	45.468	41.000	39.168	3°11'
705-060-0100	60 x 9	1000	60	59.500	55.360	54.935	50.000	47.979	2°58'
705-060-0200	60 x 9	2000	60	59.500	55.360	54.935	50.000	47.979	2°58'
705-060-0300	60 x 9	3000	60	59.500	55.360	54.935	50.000	47.979	2°58'

DIN 103 Toleranz 7e
Geradheit 0,2 - 1,0 / 300mm
Steigungsgenauigkeit 0,05 - 0,2 / 300mm

Eingängig links gerollt
Material C35

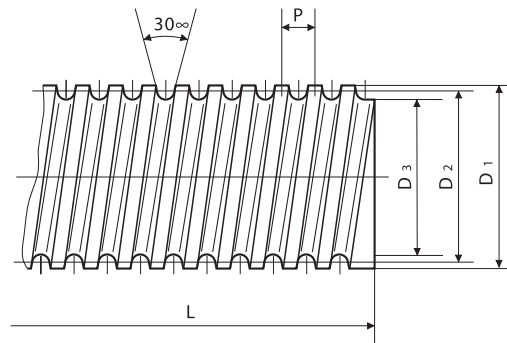

Trapezgewindespindeln eingängig links rostfrei

G&G-Best.-Nr.	DxP	L	D1 max	D1 min	D2 max	D2 min	D3 max	D3 min	Steigungswinkel
705-012-6100	12 x 3	1000	12	11.764	10.415	10.191	8.500	7.840	5°17'
705-012-6200	12 x 3	2000	12	11.764	10.415	10.191	8.500	7.840	5°17'
705-012-6300	12 x 3	3000	12	11.764	10.415	10.191	8.500	7.840	5°17'
705-016-6100	16 x 4	1000	16	15.700	13.905	13.640	11.500	10.800	5°16'
705-016-6200	16 x 4	2000	16	15.700	13.905	13.640	11.500	10.800	5°16'
705-016-6300	16 x 4	3000	16	15.700	13.905	13.640	11.500	10.800	5°16'
705-018-6100	18 x 4	1000	18	17.700	15.905	15.640	13.500	12.800	4°36'
705-018-6200	18 x 4	2000	18	17.700	15.905	15.640	13.500	12.800	4°36'
705-018-6300	18 x 4	3000	18	17.700	15.905	15.640	13.500	12.800	4°36'
705-020-6100	20 x 4	1000	20	19.700	17.905	17.640	15.500	14.800	4°05'
705-020-6200	20 x 4	2000	20	19.700	17.905	17.640	15.500	14.800	4°05'
705-020-6300	20 x 4	3000	20	19.700	17.905	17.640	15.500	14.800	4°05'
705-024-6100	24 x 5	1000	24	23.665	21.394	21.094	18.500	17.500	4°17'
705-024-6200	24 x 5	2000	24	23.665	21.394	21.094	18.500	17.500	4°17'
705-024-6300	24 x 5	3000	24	23.665	21.394	21.094	18.500	17.500	4°17'
705-026-6100	26 x 5	1000	26	25.665	23.394	23.094	20.500	19.500	3°55'
705-026-6200	26 x 5	2000	26	25.665	23.394	23.094	20.500	19.500	3°55'
705-026-6300	26 x 5	3000	26	25.665	23.394	23.094	20.500	19.500	3°55'

DIN 103 Toleranz 7e
 Geradheit 0,2 - 1,5 / 300mm
 Steigungsgenauigkeit 0,1 - 0,3 / 300mm

Eingängig links gerollt
 Material 1.4404



www.GG-ANTRIEBSTECHNIK.DE

Trapezgewindespindeln

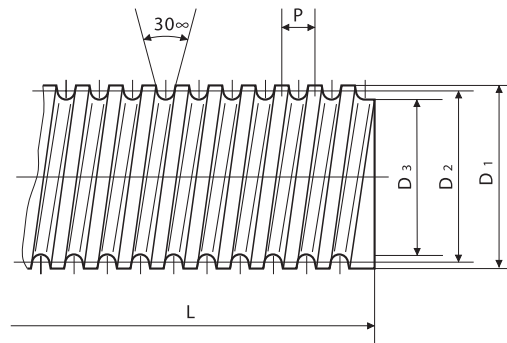

Trapezgewindespindeln eingängig links rostfrei

G&G-Best.-Nr.	DxP	L	D1 max	D1 min	D2 max	D2 min	D3 max	D3 min	Steigungswinkel
705-028-6100	28 x 5	1000	28	27.665	25.394	25.094	22.500	21.500	3°36'
705-028-6200	28 x 5	2000	28	27.665	25.394	25.094	22.500	21.500	3°36'
705-028-6300	28 x 5	3000	28	27.665	25.394	25.094	22.500	21.500	3°36'
705-030-6100	30 x 6	1000	30	29.625	26.882	26.547	23.000	21.900	4°05'
705-030-6200	30 x 6	2000	30	29.625	26.882	26.547	23.000	21.900	4°05'
705-030-6300	30 x 6	3000	30	29.625	26.882	26.547	23.000	21.900	4°05'
705-032-6100	32 x 6	1000	32	31.625	28.882	28.547	25.000	23.900	3°48'
705-032-6200	32 x 6	2000	32	31.625	28.882	28.547	25.000	23.900	3°48'
705-032-6300	32 x 6	3000	32	31.625	28.882	28.547	25.000	23.900	3°48'
705-036-6100	36 x 6	1000	36	35.625	32.882	32.547	29.000	27.900	3°20'
705-036-6200	36 x 6	2000	36	35.625	32.882	32.547	29.000	27.900	3°20'
705-036-6300	36 x 6	3000	36	35.625	32.882	32.547	29.000	27.900	3°20'
705-040-6100	40 x 7	1000	40	39.575	36.375	36.020	32.000	30.500	3°31'
705-040-6200	40 x 7	2000	40	39.575	36.375	36.020	32.000	30.500	3°31'
705-040-6300	40 x 7	3000	40	39.575	36.375	36.020	32.000	30.500	3°31'
705-050-6100	50 x 8	1000	50	49.550	45.868	45.468	41.000	39.168	3°11'
705-050-6200	50 x 8	2000	50	49.550	45.868	45.468	41.000	39.168	3°11'
705-050-6300	50 x 8	3000	50	49.550	45.868	45.468	41.000	39.168	3°11'

DIN 103 Toleranz 7e
 Geradheit 0,2 - 1,5 / 300mm
 Steigungsgenauigkeit 0,1 - 0,3 / 300mm

Eingängig links gerollt
 Material 1.4404



www.GG-ANTRIEBSTECHNIK.DE

Trapezgewindespindeln

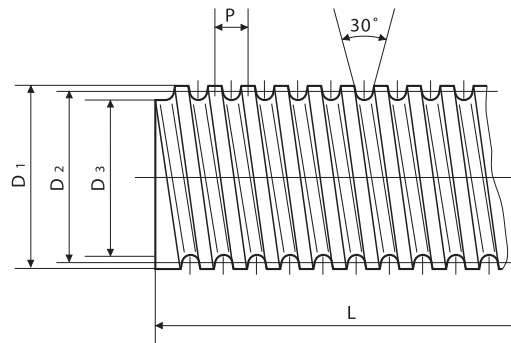

Trapezgewindespindeln zweigängig rechts C35

G&G-Best.-Nr.	DxP	L	D1 max	D1 min	D2 max	D2 min	D3 max	D3 min	Steigungswinkel
700-010-8100	10 x 4P2	1000	10	9.820	8.929	8.716	7.500	6.890	8°12'
700-010-8200	10 x 4P2	2000	10	9.820	8.929	8.716	7.500	6.890	8°12'
700-010-8300	10 x 4P2	3000	10	9.820	8.929	8.716	7.500	6.890	8°12'
700-012-8100	12 x 6P3	1000	12	11.764	10.415	10.164	8.500	7.685	10°30'
700-012-8200	12 x 6P3	2000	12	11.764	10.415	10.164	8.500	7.685	10°30'
700-012-8300	12 x 6P3	3000	12	11.764	10.415	10.164	8.500	7.685	10°30'
700-014-8100	14 x 6P3	1000	14	13.764	12.415	12.164	10.500	9.685	8°49'
700-014-8200	14 x 6P3	2000	14	13.764	12.415	12.164	10.500	9.685	8°49'
700-014-8300	14 x 6P3	3000	14	13.764	12.415	12.164	10.500	9.685	8°49'
700-016-8100	16 x 8P4	1000	16	15.700	13.905	13.608	11.500	10.474	10°29'
700-016-8200	16 x 8P4	2000	16	15.700	13.905	13.608	11.500	10.474	10°29'
700-016-8300	16 x 8P4	3000	16	15.700	13.905	13.608	11.500	10.474	10°29'
700-018-8100	18 x 8P4	1000	18	17.700	15.905	15.608	13.500	12.474	9°20'
700-018-8200	18 x 8P4	2000	18	17.700	15.905	15.608	13.500	12.474	9°20'
700-018-8300	18 x 8P4	3000	18	17.700	15.905	15.608	13.500	12.474	9°20'
700-020-8100	20 x 8P4	1000	20	19.700	17.905	17.608	15.500	14.474	8°09'
700-020-8200	20 x 8P4	2000	20	19.700	17.905	17.608	15.500	14.474	8°09'
700-020-8300	20 x 8P4	3000	20	19.700	17.905	17.608	15.500	14.474	8°09'
700-022-8100	22 x 10P5	1000	22	21.665	19.394	19.058	16.500	15.294	9°23'
700-022-8200	22 x 10P5	2000	22	21.665	19.394	19.058	16.500	15.294	9°23'
700-022-8300	22 x 10P5	3000	22	21.665	19.394	19.058	16.500	15.294	9°23'
700-024-8100	24 x 10P5	1000	24	23.665	21.394	21.058	18.500	17.269	8°31'
700-024-8200	24 x 10P5	2000	24	23.665	21.394	21.058	18.500	17.269	8°31'
700-024-8300	24 x 10P5	3000	24	23.665	21.394	21.058	18.500	17.269	8°31'

DIN 103 Toleranz 7e
Geradheit 0,2 - 1,0 / 300mm
Steigungsgenauigkeit 0,05 - 0,2 / 300mm

Zweigängig rechts gerollt
Material C35



www.GG-ANTRIEBSTECHNIK.DE

Trapezgewindespindeln

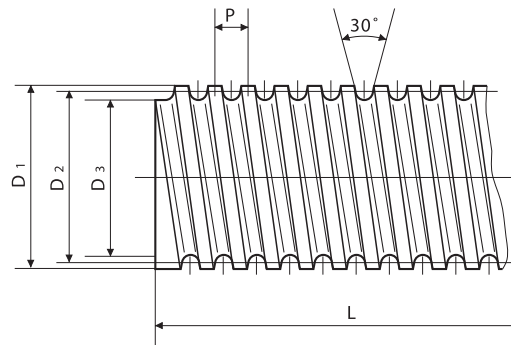

Trapezgewindespindeln zweigängig rechts C35

G&G-Best.-Nr.	DxP	L	D1 max	D1 min	D2 max	D2 min	D3 max	D3 min	Steigungswinkel
700-026-8100	26 x 10P5	1000	26	25.665	23.394	23.058	20.500	19.269	7°48'
700-026-8200	26 x 10P5	2000	26	25.665	23.394	23.058	20.500	19.269	7°48'
700-026-8300	26 x 10P5	3000	26	25.665	23.394	23.058	20.500	19.269	7°48'
700-028-8100	28 x 10P5	1000	28	27.665	25.394	25.058	22.500	21.269	7°12'
700-028-8200	28 x 10P5	2000	28	27.665	25.394	25.058	22.500	21.269	7°12'
700-028-8300	28 x 10P5	3000	28	27.665	25.394	25.058	22.500	21.269	7°12'
700-030-8100	30 x 12P6	1000	30	29.625	26.882	26.507	23.000	21.563	8°08'
700-030-8200	30 x 12P6	2000	30	29.625	26.882	26.507	23.000	21.563	8°08'
700-030-8300	30 x 12P6	3000	30	29.625	26.882	26.507	23.000	21.563	8°08'
700-032-8100	32 x 12P6	1000	32	31.625	28.882	28.507	25.000	23.563	7°34'
700-032-8200	32 x 12P6	2000	32	31.625	28.882	28.507	25.000	23.563	7°34'
700-032-8300	32 x 12P6	3000	32	31.625	28.882	28.507	25.000	23.563	7°34'
700-036-8100	36 x 12P6	1000	36	35.625	32.882	32.507	29.000	27.563	6°39'
700-036-8200	36 x 12P6	2000	36	35.625	32.882	32.507	29.000	27.563	6°39'
700-036-8300	36 x 12P6	3000	36	35.625	32.882	32.507	29.000	27.563	6°39'
700-040-8100	40 x 14P7	1000	40	39.575	36.375	35.978	32.000	30.381	7°01'
700-040-8200	40 x 14P7	2000	40	39.575	36.375	35.978	32.000	30.381	7°01'
700-040-8300	40 x 14P7	3000	40	39.575	36.375	35.978	32.000	30.381	7°01'

DIN 103 Toleranz 7e
 Geradheit 0,2 - 1,0 / 300mm
 Steigungsgenauigkeit 0,05 - 0,2 / 300mm

Zweigängig rechts gerollt
 Material C35