

Antriebstechnik

Kegelräder Typ B Übersetzung 1:1

Kegelräder Typ B Übersetzung 1:1,5

Kegelräder Typ B Übersetzung 1:2

Kegelräder Typ B Übersetzung 1:3

Kegelräder Typ B Übersetzung 1:4

Sonderanfertigungen komplett nach Ihrer Zeichnung sowie mechanische Bearbeitung von Standardteilen auf Anfrage.

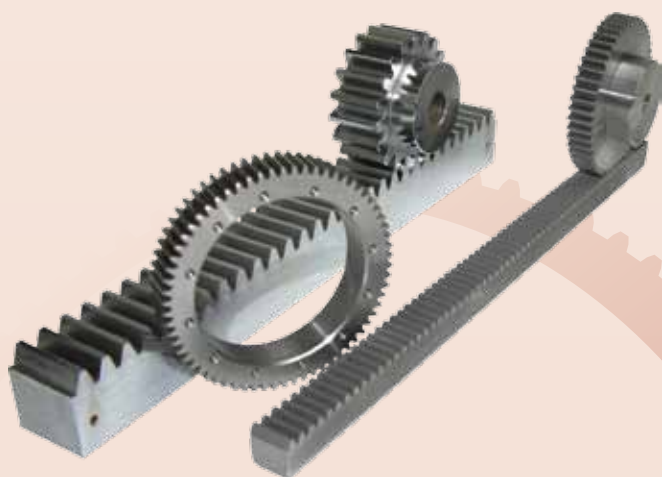

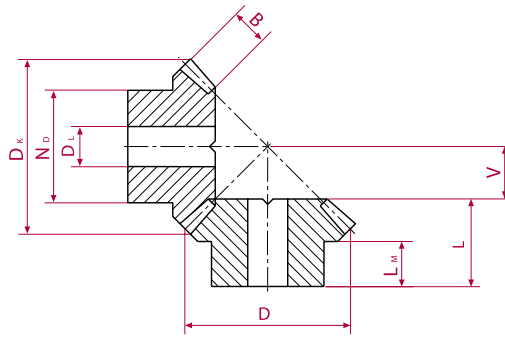

Kegelräder B 1:1

GG-Bestell-Nr.	Modul	Zz	D _k	D	B	N _D	D _L	L	V	L _M	S
451-010-1016	1	16	17.40	16.0	4.0	13.3	4.0	11.2	4.80	6.5	-
451-010-1019	1	19	20.40	19.0	4.0	15.3	4.0	11.8	6.20	6.5	-
451-010-1022	1	22	23.40	22.0	4.7	16.3	5.0	12.8	7.20	6.5	-
451-010-1026	1	26	27.40	26.0	5.5	20.3	5.0	13.3	8.70	7.0	-
451-010-1030	1	30	31.40	30.0	6.4	20.3	5.0	16.0	10.00	8.0	-
451-015-1016	1.5	16	26.10	24.0	6.0	20.3	8.0	18.9	7.10	12.0	-
451-015-1019	1.5	19	30.60	28.5	7.0	20.3	8.0	21.3	8.70	12.0	-
451-015-1022	1.5	22	35.10	33.0	7.5	25.3	8.0	22.5	10.50	12.0	-
451-015-1026	1.5	26	41.10	39.0	8.5	28.3	8.0	23.2	12.80	12.0	-
451-015-1030	1.5	30	47.10	45.0	10.0	30.3	12.0	27.2	14.80	12.0	-
451-020-1016	2	16	34.80	32.0	8.0	25.3	8.0	23.5	9.50	14.0	-
451-020-1019	2	19	40.80	38.0	9.0	25.3	8.0	24.2	11.80	12.0	-
451-020-1022	2	22	46.80	44.0	10.0	30.3	12.0	27.9	14.10	14.0	-
451-020-1026	2	26	54.80	52.0	12.0	35.3	12.0	31.4	16.60	14.0	-
451-020-1030	2	30	62.80	60.0	13.0	40.3	14.0	34.1	19.90	17.0	-
451-025-1016	2.5	16	43.50	40.0	10.0	30.3	12.0	28.1	11.90	15.0	-
451-025-1019	2.5	19	51.00	47.5	11.0	35.3	12.0	27.1	14.90	13.0	-
451-025-1022	2.5	22	58.50	55.0	12.0	45.3	16.0	30.1	17.90	16.0	-
451-025-1026	2.5	26	68.50	65.0	15.0	45.3	16.0	33.2	20.80	16.0	-
451-025-1030	2.5	30	78.50	75.0	16.0	50.3	16.0	39.0	25.00	20.0	-
451-030-1016	3	16	52.50	48.0	12.0	40.3	12.0	31.7	14.30	18.0	-
451-030-1019	3	19	61.20	57.0	13.0	40.3	14.0	36.0	18.00	17.0	-
451-030-1022	3	22	70.20	66.0	15.0	50.3	16.0	36.9	21.10	17.0	-
451-030-1026	3	26	82.20	78.0	17.0	50.3	16.0	38.4	25.60	18.0	-
451-030-1030	3	30	94.20	90.0	19.0	60.3	20.0	43.8	30.20	22.0	-

geradverzahnt
20° Eingriffswinkel
90° Achswinkel
Material C45

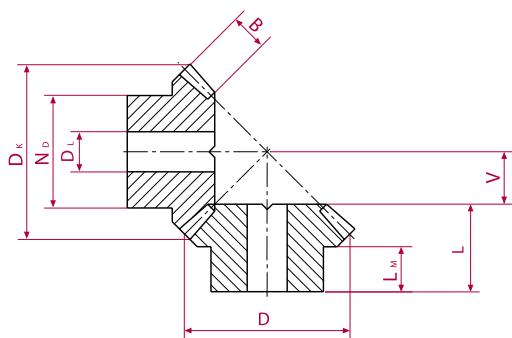

Kegelräder B 1:1

GG-Bestell-Nr.	Modul	Zz	D _k	D	B	N _D	D _L	L	V	L _M	S
451-035-1016	3.5	16	60.90	56.0	14.0	45.3	16.0	36.4	16.60	20.0	-
451-035-1019	3.5	19	71.50	66.5	15.0	50.3	18.0	37.8	21.00	19.0	-
451-035-1022	3.5	22	81.90	77.0	17.0	55.3	20.0	39.1	24.90	18.0	-
451-035-1026	3.5	26	96.00	91.0	20.0	62.3	20.0	43.4	29.70	20.0	-
451-035-1030	3.5	30	110.00	105.0	23.0	70.3	20.0	47.1	34.90	22.0	-
451-040-1016	4	16	69.70	64.0	15.0	50.3	16.0	44.3	19.70	25.0	-
451-040-1019	4	19	81.70	76.0	18.0	55.3	20.0	44.4	23.60	22.0	-
451-040-1022	4	22	93.70	88.0	20.0	60.3	20.0	45.9	28.10	22.0	-
451-040-1026	4	26	109.70	104.0	25.0	70.3	20.0	48.0	34.00	22.0	-
451-040-1030	4	30	125.70	120.0	26.0	80.3	25.0	54.2	39.80	25.0	-
451-045-1016	4.5	16	78.40	72.0	17.5	55.3	20.0	46.3	21.70	25.0	-
451-045-1019	4.5	19	91.80	85.5	20.0	62.3	20.0	49.0	26.57	25.0	-
451-045-1022	4.5	22	105.30	99.0	22.0	70.3	20.0	50.1	31.90	25.0	-
451-045-1026	4.5	26	123.00	117.0	25.0	75.3	20.0	54.7	38.60	26.0	-
451-045-1030	4.5	30	141.40	135.0	29.0	80.3	25.0	60.0	45.00	28.0	-
451-050-1016	5	16	87.10	80.0	18.0	60.3	20.0	48.9	25.10	25.0	-
451-050-1019	5	19	102.10	95.0	22.0	60.3	20.0	52.2	29.80	25.0	-
451-050-1022	5	22	117.10	110.0	24.0	80.3	25.0	58.2	35.80	30.0	-
451-050-1026	5	26	137.10	130.0	29.0	80.3	25.0	62.7	42.30	30.0	-
451-050-1030	5	30	157.10	150.0	32.0	80.3	30.0	68.9	50.10	35.0	-

geradverzahnt
 20° Eingriffswinkel
 90° Achswinkel
 Material C45

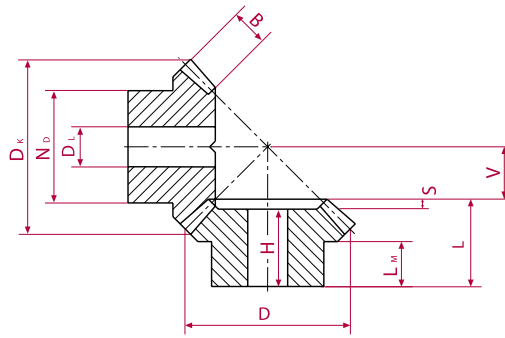

Kegelräder B 1:1,5

GG-Bestell-Nr.	Modul	Z _z	D _K	D	B	N _D	D _L	L	V	H	L _M	S
	1	16	18.10	16.0	4.3	13.3	4.0	12.0	8.00		7.0	
451-010-1624	1	24	24.80	24.0	4.3	20.3	5.0	14.8	5.20	13.3	9.3	1.5
	1.5	16	27.10	24.0	8.0	20.3	8.0	20.3	10.70		11.8	
451-015-1624	1.5	24	37.20	36.0	8.0	28.3	8.0	24.9	7.10	22.7	16.0	2.2
	2	16	36.20	32.0	10.0	25.3	8.0	25.2	14.80		13.8	
451-020-1624	2	24	49.70	48.0	10.0	32.3	8.0	27.2	9.80	24.7	16.0	2.5
	2.5	16	45.20	40.0	13.0	32.3	12.0	30.8	18.20		16.4	
451-025-1624	2.5	24	62.10	60.0	13.0	45.3	16.0	34.0	12.00	30.8	20.0	3.2
	3	16	54.30	48.0	14.5	40.3	12.0	32.4	22.60		16.4	
451-030-1624	3	24	74.50	72.0	14.5	55.3	16.0	36.2	14.80	32.0	20.0	4.2
	3.5	16	63.30	56.0	18.0	45.3	16.0	40.4	25.60		20.4	
451-035-1624	3.5	24	86.90	84.0	18.0	55.3	20.0	44.2	16.80	40.0	25.0	4.2
	4	16	72.40	64.0	18.0	50.3	16.0	46.8	31.20		25.4	
451-040-1624	4	24	99.30	96.0	18.0	60.3	20.0	45.5	20.50	40.0	25.0	5.5
	4.5	16	81.40	72.0	20.0	60.3	20.0	47.6	35.40		25.1	
451-045-1624	4.5	24	111.70	108.0	20.0	80.3	25.0	57.8	23.20	51.3	35.0	6.5
	5	16	90.50	80.0	24.0	60.3	25.0	54.1	37.90		25.4	
451-050-1624	5	24	124.10	120.0	24.0	80.3	30.0	61.1	24.90	54.5	35.0	6.6

geradverzahnt
20° Eingriffswinkel
90° Achswinkel
Material C45

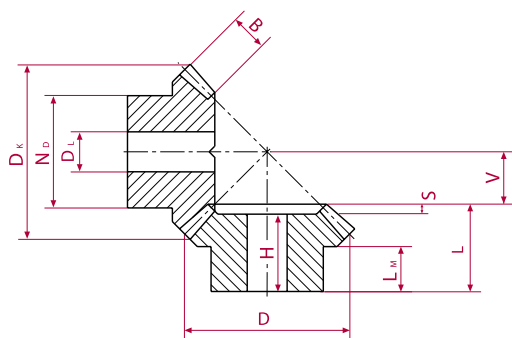

Kegelräder B 1:2

GG-Bestell-Nr.	Modul	Zz	D _K	D	B	N _D	D _L	L	V	H	L _M	S
	1	15	17.40	15.0	5.0	13.3	4.0	11.9	10.10		6.5	
451-010-1530	1	30	30.60	30.0	5.0	20.3	5.0	15.1	4.90	13.7	9.0	1.4
	1.5	15	26.10	22.5	9.0	19.3	8.0	21.1	13.90		11.9	
451-015-1530	1.5	30	45.90	45.0	9.0	32.3	8.0	25.2	6.80	21.0	16.0	2.2
	2	15	34.80	30.0	11.5	25.3	8.0	26.0	19.00		14.1	
451-020-1530	2	30	61.20	60.0	11.5	40.3	14.0	29.8	9.20	26.8	18.0	3.0
	2.5	15	43.50	37.5	15.0	32.3	12.0	31.8	23.20		16.2	
451-025-1530	2.5	30	76.50	75.0	15.0	45.3	16.0	33.7	11.30	30.0	20.0	3.7
	3	15	52.20	45.0	17.0	40.3	12.0	37.3	28.70		19.9	
451-030-1530	3	30	91.80	90.0	17.0	55.3	16.0	42.1	13.90	38.0	25.0	4.1
	3.5	15	60.90	52.5	20.5	45.3	16.0	46.1	32.90		24.7	
451-035-1530	3.5	30	107.10	105.0	20.5	60.3	20.0	45.0	16.00	40.0	25.0	5.0
	4	15	69.60	60.0	22.5	50.3	20.0	48.6	38.40		24.6	
451-040-1530	4	30	122.30	120.0	22.5	80.3	25.0	57.3	18.70	51.9	35.0	5.4
	4.5	15	78.30	67.5	26.0	60.3	20.0	51.4	42.60		24.7	
451-045-1530	4.5	30	137.60	135.0	26.0	80.3	30.0	60.3	20.70	54.3	35.0	6.0
	5	15	87.00	75.0	30.0	60.3	25.0	57.6	46.40		25.3	
451-050-1530	5	30	152.90	150.0	30.0	80.3	30.0	62.5	22.50	56.0	35.0	6.5

geradverzahnt
 20° Eingriffswinkel
 90° Achswinkel
 Material C45

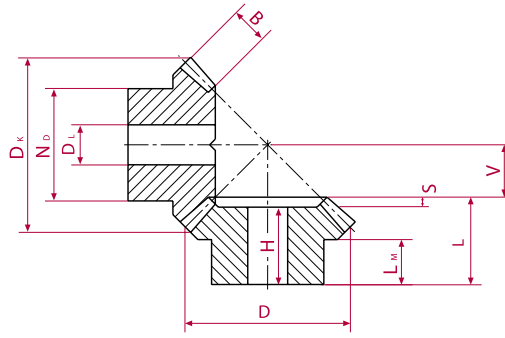

Kegelräder B 1:3

GG-Bestell-Nr.	Modul	Zz	D _K	D	B	N _D	D _L	L	V	H	L _M	S
	1	15	17.70	15.0	7.1	13.3	4.0	16.6	15.40		9.2	
451-010-1545	1	45	45.30	45.0	7.1	25.3	8.0	17.1	4.90	15.2	10.0	1.9
	1.5	15	26.50	22.5	10.5	19.3	8.0	22.6	23.40		11.7	
451-015-1545	1.5	45	68.10	67.5	10.5	45.3	14.0	29.6	7.40	27.2	20.0	2.4
	2	15	35.40	30.0	14.0	25.3	8.0	28.9	31.10		14.2	
451-020-1545	2	45	90.80	90.0	14.0	45.3	16.0	32.1	9.90	28.4	20.0	3.7
	2.5	15	44.10	37.5	18.0	32.3	12.0	34.6	38.40		15.9	
451-025-1545	2.5	45	113.40	112.5	18.0	60.3	20.0	39.7	12.30	35.3	25.0	4.4
	3	15	53.00	45.0	21.0	40.3	16.0	41.3	46.70		19.7	
451-030-1545	3	45	136.10	135.0	21.0	60.3	25.0	47.2	14.80	42.0	30.0	5.2
	3.5	15	61.90	52.5	23.5	45.3	20.0	49.6	55.40		25.0	
451-035-1545	3.5	45	158.80	157.5	23.5	80.3	25.0	54.4	17.60	48.6	35.0	5.8
	4	15	70.70	60.0	27.5	50.3	20.0	54.3	62.70		25.4	
451-040-1545	4	45	181.50	180.0	27.5	80.3	30.0	57.0	20.00	50.5	35.0	6.5
	4.5	15	79.50	67.5	28.5	55.3	25.0	55.2	72.80		24.8	
451-045-1545	4.5	45	204.20	202.5	28.5	90.3	30.0	63.9	23.10	57.0	40.0	6.9
	5	15	88.40	75.0	33.0	60.3	25.0	65.3	79.70		30.0	
451-050-1545	5	45	226.90	225.0	33.0	90.3	30.0	66.7	25.30	59.2	40.0	7.5

geradverzahnt
20° Eingriffswinkel
90° Achswinkel
Material C45

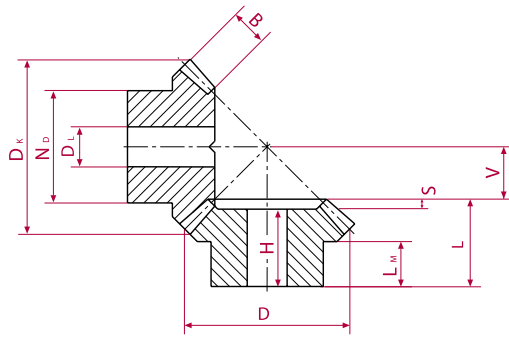

Kegelräder B 1:4

GG-Bestell-Nr.	Modul	Zz	D _K	D	B	N _b	D _L	L	V	H	L _M	S
	1	15	17.80	15.0	9.3	13.3	4.0	17.2	20.80		7.7	
451-010-1560	1	60	60.30	60.0	9.3	30.3	8.0	17.1	4.90	15.2	10.0	1.9
	1.5	15	26.70	22.5	11.0	20.3	8.0	23.0	34.00		11.7	
451-015-1560	1.5	60	90.40	90.0	11.0	50.3	16.0	34.0	8.00	31.2	25.0	2.8
	2	15	35.60	30.0	16.0	25.3	8.0	31.0	44.00		14.4	
451-020-1560	2	60	120.60	120.0	16.0	60.3	16.0	37.6	10.40	34.2	25.0	3.4
	2.5	15	44.50	37.5	19.0	32.3	14.0	38.1	55.90		18.4	
451-025-1560	2.5	60	150.70	150.0	19.0	60.3	20.0	44.8	13.20	40.0	30.0	4.8
	3	15	53.30	45.0	23.0	40.3	16.0	48.1	66.90		24.5	
451-030-1560	3	60	100.80	180.0	23.0	80.3	25.0	53.2	15.80	48.2	35.0	5.0
	3.5	15	62.20	52.5	26.0	45.3	20.0	52.1	78.90		25.1	
451-035-1560	3.5	60	211.00	210.0	26.0	90.3	30.0	60.4	18.60	54.4	40.0	6.0
	4	15	71.10	60.0	30.0	50.3	20.0	55.1	89.90		23.0	
451-040-1560	4	60	241.10	240.0	30.0	90.3	30.0	60.8	21.20	53.0	40.0	7.8
	4.5	15	79.97	67.5	32.0	52.3	20.0	57.0	102.90		23.0	
451-045-1560	4.5	60	271.24	270.0	32.0	90.3	30.0	62.0	24.30	53.5	40.0	8.5
	5	15	88.80	75.0	34.0	55.3	20.0	62.0	115.70		25.0	
451-050-1560	5	60	301.30	300.0	34.0	90.3	30.0	65.0	27.00	55.0	40.0	10.0

geradverzahnt
 20° Eingriffswinkel
 90° Achswinkel
 Material C45